

BACK VIEW II SCALE 1:5

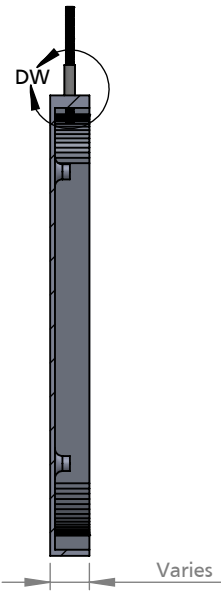

SECTION VIEW A-A II SCALE 1:5

NOTE: Styles with thin strokes or small letters may be cast solid

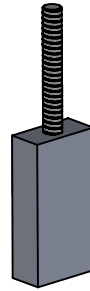

<1/2" use 10-24 studs
1/2"+ return use 1/4-20 studs

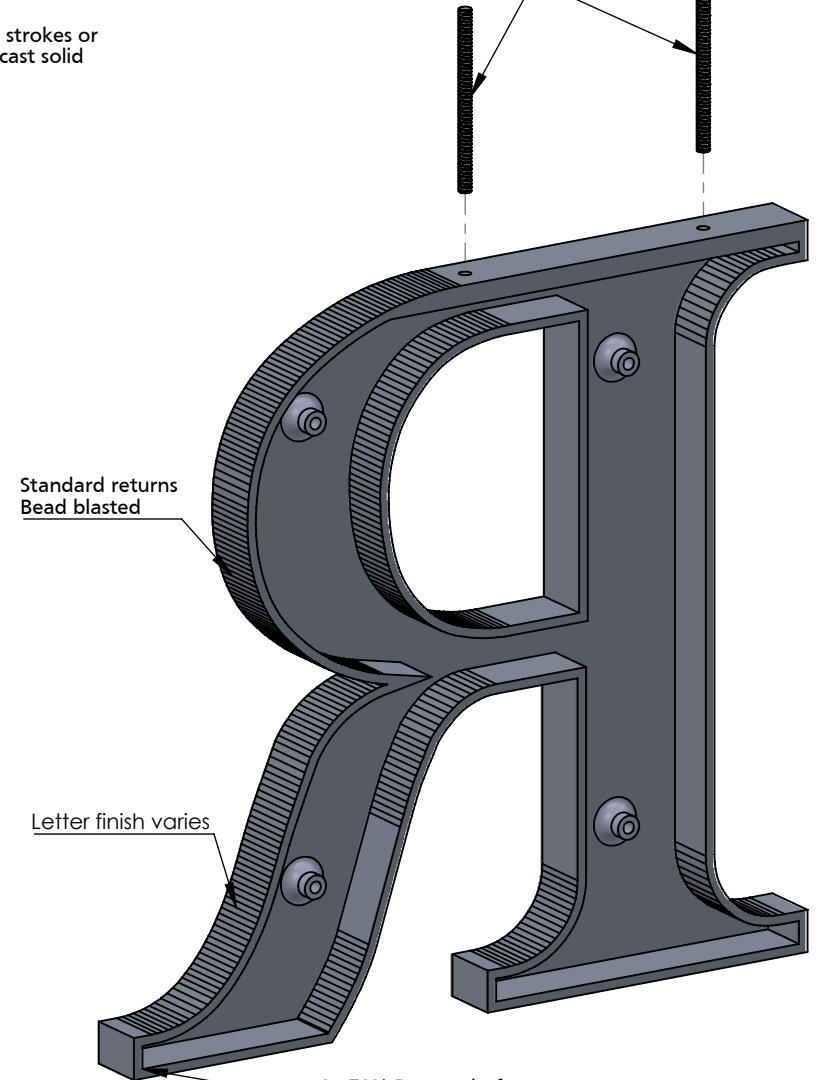

ISOMETRIC BACK VIEW II SCALE 1:3

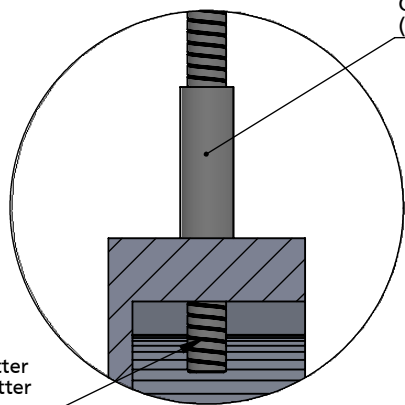

Optional spacer sleeve
(Size varies)

Aluminum stud w/aluminum letter
Stainless steel stud w/bronze letter
(type and size varies)

DETAIL DW II SCALE 1:1

NOTES:
Letters 4"- 24" Minimum 3/8" thick
Tie back required (not supplied) on letters >8" high
Typical stud length 2" beyond back of letter
Letters <15" - 10/24 studs, 15"+ - 1/4-20 studs.
Standard cast studs are in line for brick mortar (2-5/8" - CM)

TITLE:

CAST METAL TOP STUD MOUNT

MATERIAL:

ALUMINUM OR BRONZE

PRODUCT TYPE:

CAST METAL

DWG NO. CAST30

REV 11/20/14

SCALE: AS INDICATED

SHEET 1 OF 1