

BACK VIEW II SCALE 1:5

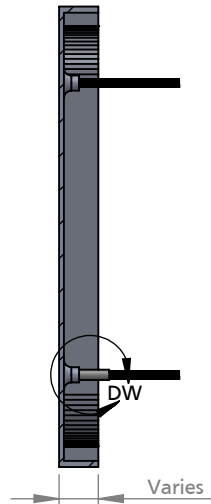

SECTION VIEW A-A II SCALE 1:5

NOTE: Styles with thin strokes or small letters may be cast solid

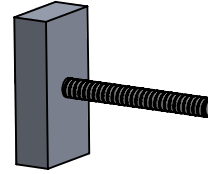

Standard returns
Bead blasted

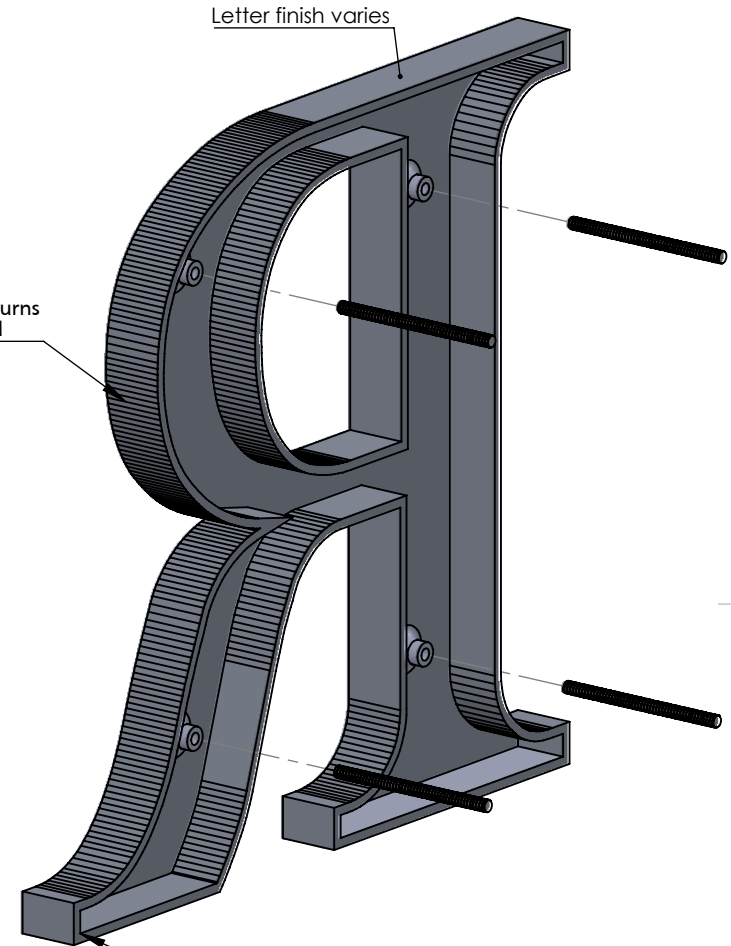

ISOMETRIC BACK VIEW II SCALE 1:3

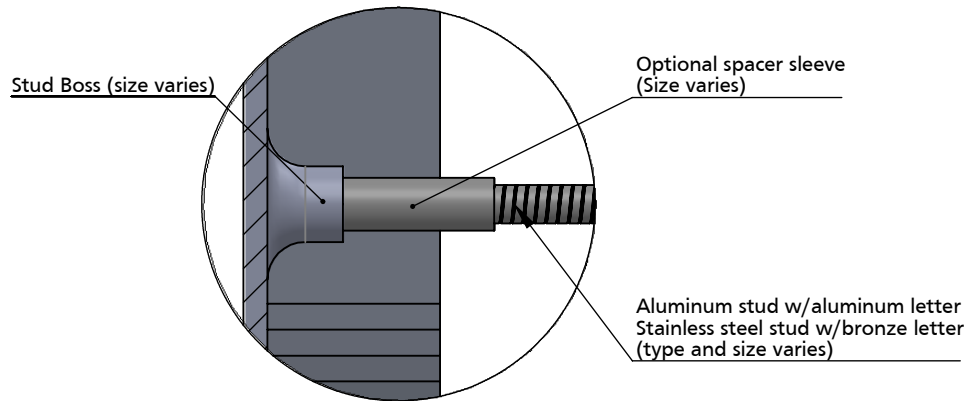

DETAIL DW II SCALE 1:1

SIZE	MIN STUDS/LTR
Up to 3"	3 studs
over 3" - 15"	4 studs
Over 15"	6 studs
Punctuation	2 studs

NOTES:
 Typical stud length 2" beyond back of letter
 Letters under 15" high - 10/24 studs, 15"+ high - 1/4-20 studs.
 Less than 3/8" stroke, 6-32 or 4-40 studs
 Standard cast studs are in line for brick mortar (2-5/8" on center for mortar)

TITLE:

CAST METAL STUD MOUNT

MATERIAL:

ALUMINUM OR BRONZE

PRODUCT TYPE:

CAST METAL