

PRODUCT CONSTRUCTION EXAMPLE

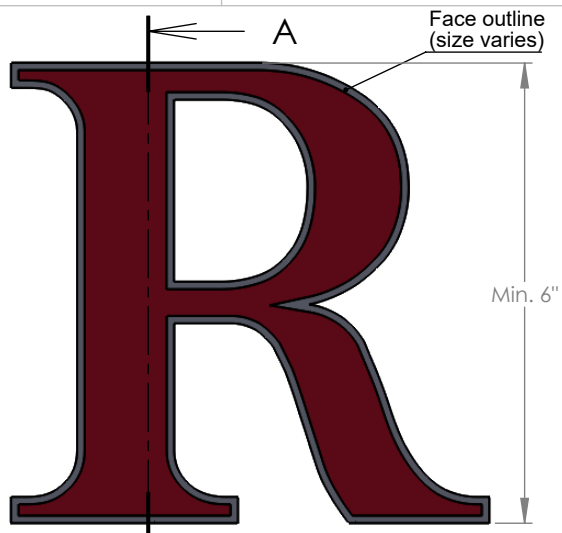

FRONT VIEW II SCALE 1:5

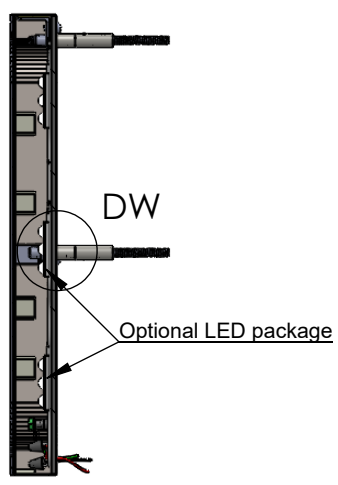

SECTION A-A II SCALE 1:5

24 gauge return material - up to 24" high
22 gauge return material - over 24" high

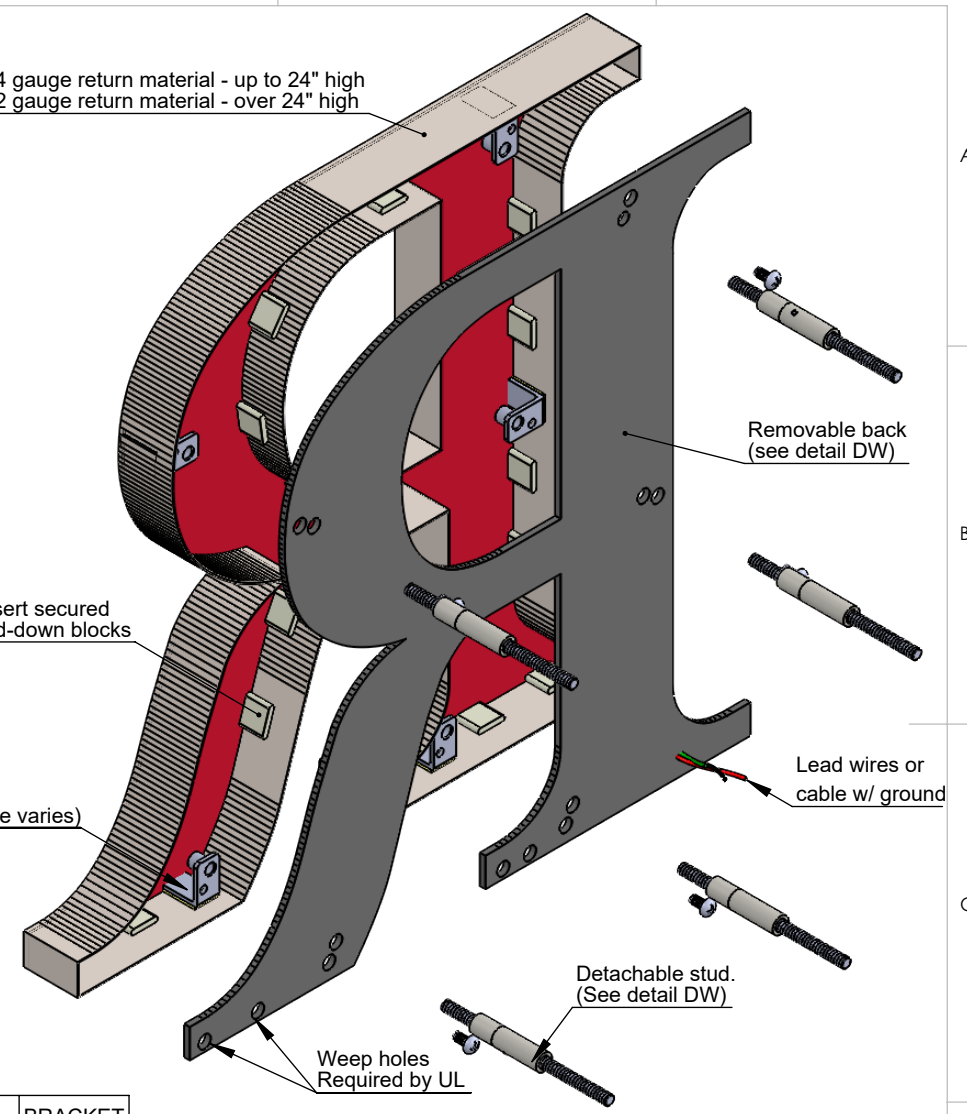

ISOMETRIC BACK VIEW II SCALE 1:3

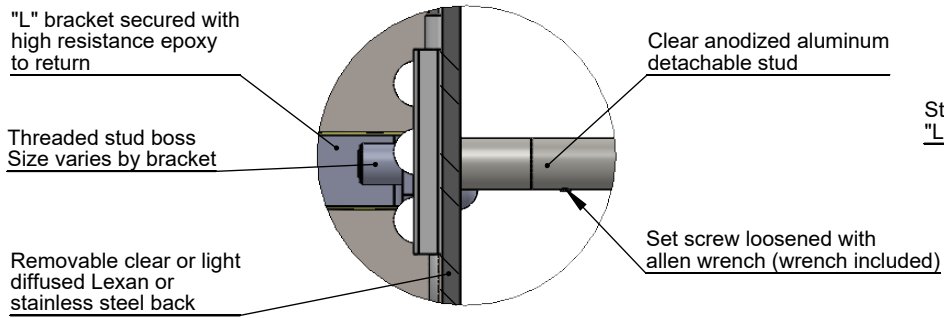

DETAIL DW II SCALE 1:1

BACK OPTIONS

- Clear Lexan: 6-12" high - 0.118 thick
- Light diffused Lexan: 0.177" thick
- Stainless steel - same gauge as face

INSERT OPTIONS	
Stainless steel	18-20 gauge up to 24" high
	16-18 gauge over 24" to 36" high
Acrylic	3/16" thick - up to 36" high

LETTER SIZE	MIN. DEPTH	STUD	BRACKET
6" to 24"	1.0"	10 - 24	Medium
over 24"	1.75"	1/4 - 20	Large

- NOTES:**
- Minimum 1" stroke for LEDs, min. 2" deep
 - Lead wires or optional cable wire available
 - Optional: UL listed - LED halo lit package shown
 - Metal back - Pan-head screw slightly recessed
 - Lexan back - Flush stainless steel screw
 - Tie backs required (not supplied) on letters > 8" high

- MATERIAL OPTIONS**
- Standard - 304 prefinished stainless steel
 - Optional - 316 prefinished stainless steel (more corrosion resistant)
 - 304 prefinished stainless with titanium coating



TITLE: FACE LIT - WITH LEDS - DETACHABLE STUD	
MATERIAL: STAINLESS STEEL	PRODUCT TYPE: FABRICATED METAL
DWG NO. FABL230L	REV 12/3/16
SCALE: AS INDICATED	SHEET 1 OF 1