

FRONT VIEW II SCALE 1:5

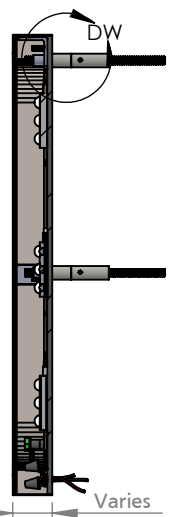

SECTION A-A II SCALE 1:5

24 gauge return material - up to 24" high
22 gauge return material - over 24" high

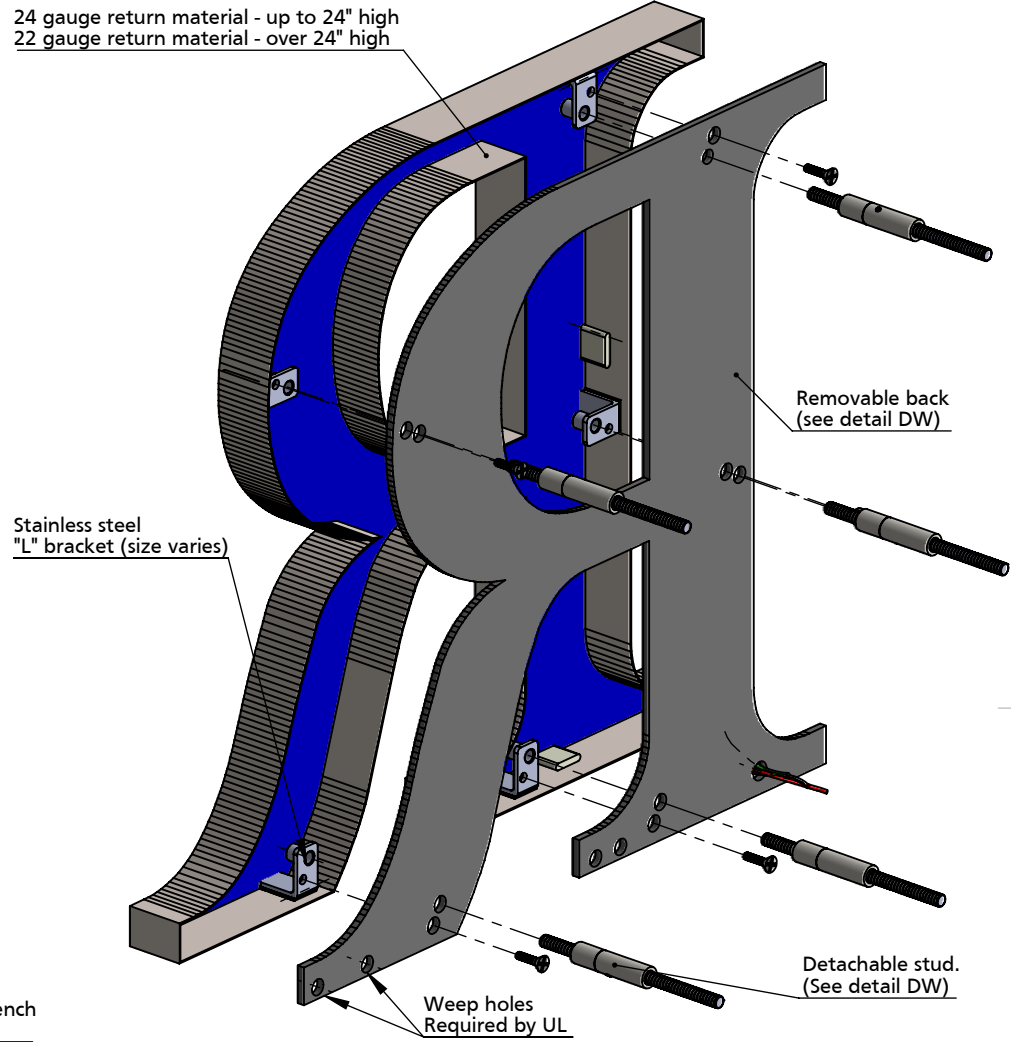

ISOMETRIC BACK VIEW II SCALE 1:3

"L" bracket secured with high resistance epoxy to return

Flush back secured with stainless steel screw

Threaded Stud Boss
Size varies by bracket

Removable clear or light diffused Lexan or stainless steel back.

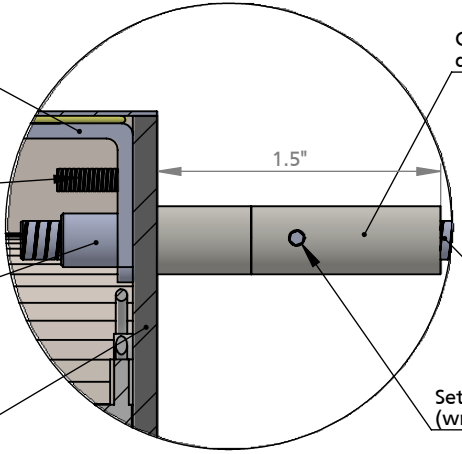

Clear anodized aluminum detachable stud.

Stainless steel Mounting Stud
Size varies (see table)

Set screw loosened with Allen wrench (wrench included)

DETAIL DW II SCALE 1:1

BACK OPTIONS

- Clear Lexan: 6-12" high - 0.118 thick.
- Light diffused Lexan: 0.177" thick
- Stainless steel - same gauge as face (optional: 1/8" thick metal back)

INSERT OPTIONS	
Stainless steel	18-20 gauge up to 24" high
	16-18 gauge over 24" to 36" high
Acrylic	3/16" thick - up to 36" high

MATERIAL OPTIONS

- Standard - 304 prefinished stainless steel
- Optional - 316 prefinished stainless steel (more corrosion resistant)
- 304 prefinished stainless with titanium coating



TITLE: CUT OUT FACE WITH INSERT - BACK - LED DETACHABLE STUD	
MATERIAL: STAINLESS STEEL	PRODUCT TYPE: FABRICATED METAL
DWG NO. FABL230	REV 11/07/14
SCALE: AS INDICATED	SHEET 1 OF 1