

FRONT VIEW II SCALE 1:5

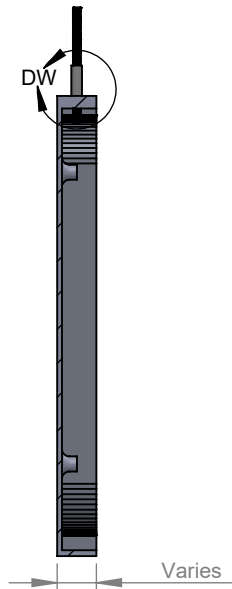

SECTION VIEW A-A II SCALE 1:5

NOTE: Styles with thin strokes or small letters may be cast solid

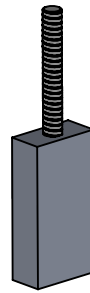

Standard returns
Bead blasted

Threaded studs

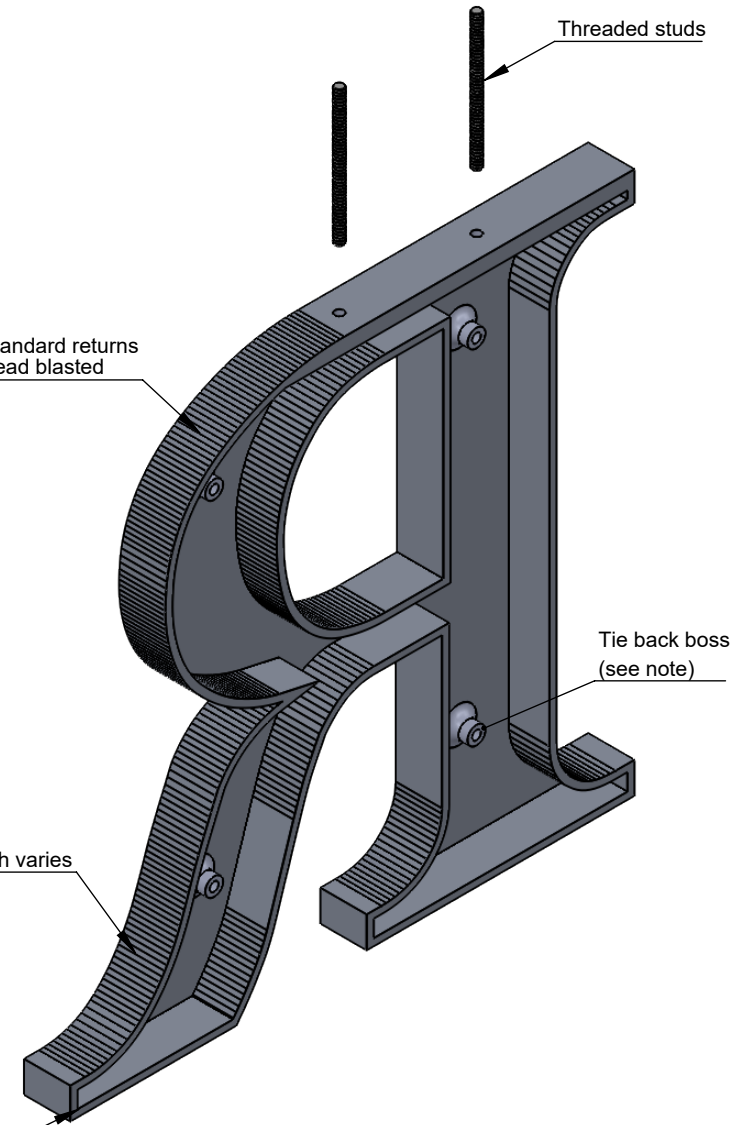

ISOMETRIC BACK VIEW II SCALE 1:3

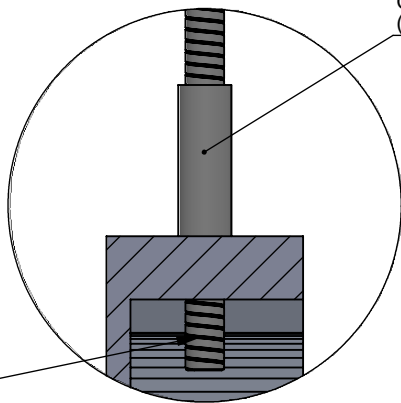

DETAIL DW II SCALE 1:1

0 - 7° return draft - thickness/depth
- varies by style and height

NOTES:

- Letters 4"- 24" Minimum 3/8" thick
- Tie back required (not supplied) on letters >8" high
- Typical stud length 2" beyond top of letter
- Round letters (O, C, G, Q, S) sanded flat on top- optional
- Minimum 2 studs per letter
- 3/8" - 1/2" deep, 4-6" high, 10/24 stainless steel studs
- Over 1/2" deep, or over 6" high, 1/4-20 stainless steel studs
- Standard catalog styles or customer per vector art. Flat faced/round/prismatic profile options. Typical 3/16" - 1/4" wall thickness on hollow back letters/logos.
- Letters or logos, standard or custom



TITLE:

CAST METAL TOP STUD MOUNT

MATERIAL:

ALUMINUM OR BRONZE

PRODUCT TYPE:

CAST METAL

DWG NO. CAST30

REV 10/26/16

SCALE: AS INDICATED

SHEET 1 OF 1