

PRODUCT CONSTRUCTION EXAMPLE

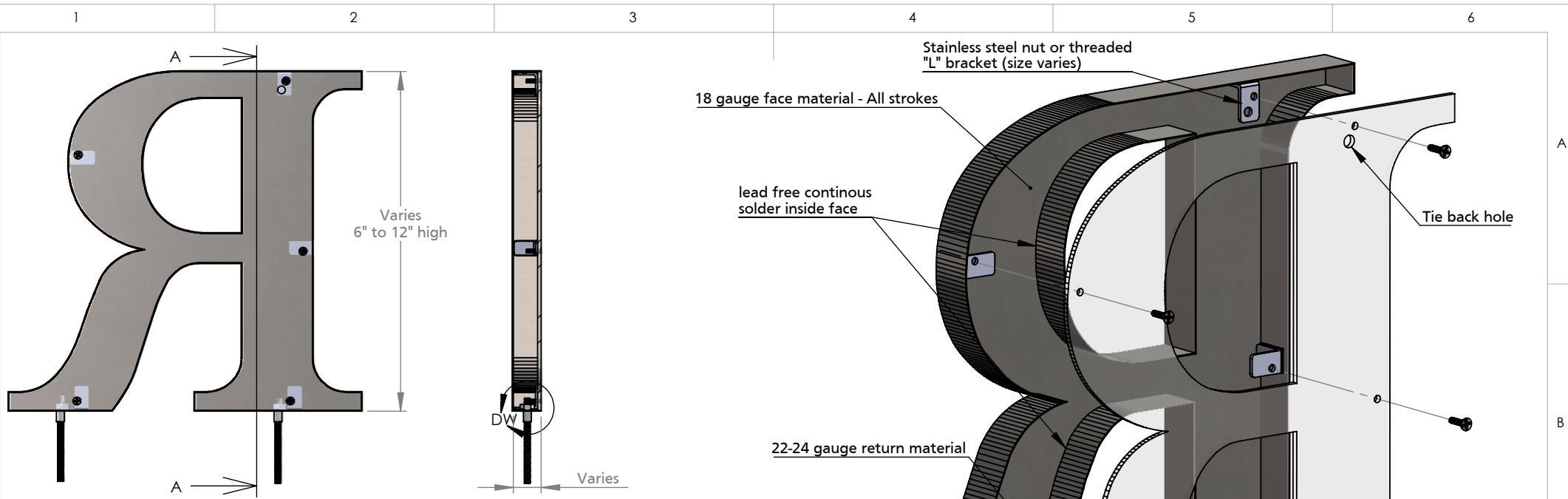

BACK VIEW II SCALE 1:5

SECTION VIEW A-A II SCALE 1:5

ISOMETRIC BACK VIEW II SCALE 1:3

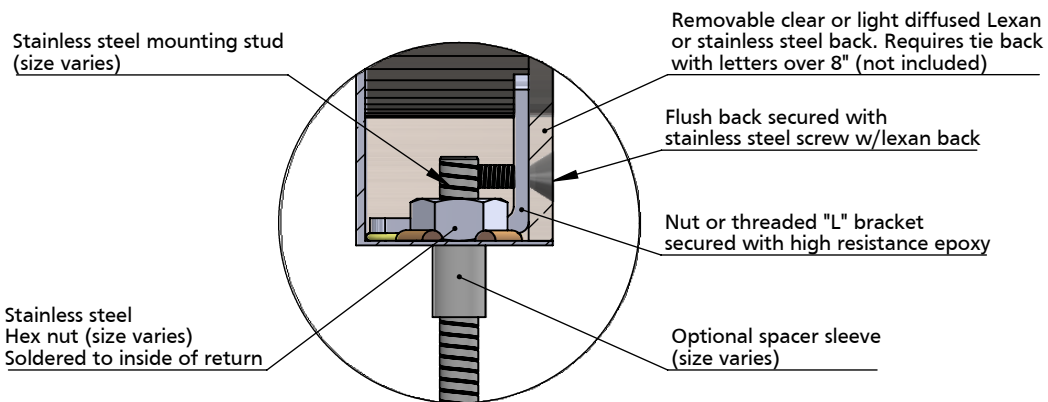

DETAIL DW II SCALE 1:1

BACK OPTIONS

- Clear Lexan: 6-12" high - 0.118 thick
- Light diffused Lexan: 0.177" thick
- Stainless steel - same gauge as face

MATERIAL OPTIONS

- Standard - 304 prefinished stainless steel
- Optional - 316 prefinished stainless steel (more corrosion resistant)
- 304 prefinished stainless with titanium coating



TITLE:

METAL FACE WITH BACK - BOTTOM STUD MOUNT

MATERIAL:

STAINLESS STEEL

PRODUCT TYPE:

FABRICATED METAL

DWG NO. FABL60

REV 04/07/15

SCALE: AS INDICATED

SHEET 1 OF 1