

BACK VIEW II SCALE 1:5

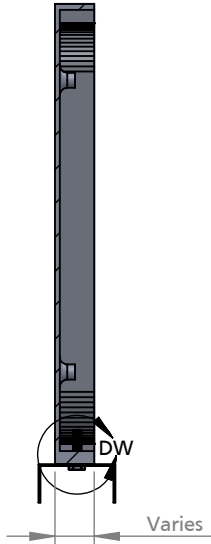

SECTION VIEW A-A II SCALE 1:5

NOTE: Styles with thin strokes or small letters may be cast solid

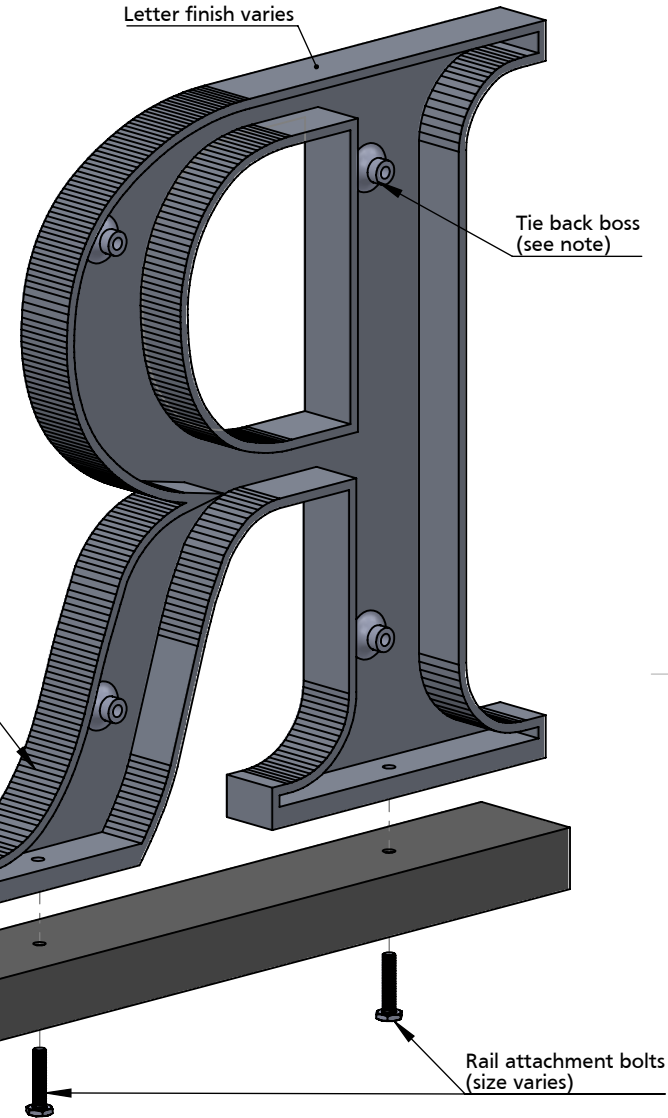
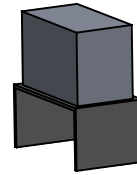

ISOMETRIC BACK VIEW II SCALE 1:3

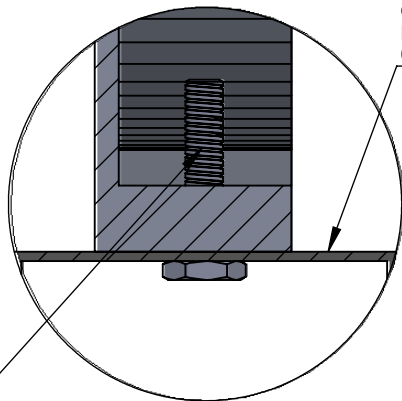

DETAIL DW II SCALE 1:1

C-shape rail (size varies)
Painted or anodized
6063-T2 extruded-aluminum

Threaded aluminum bolt
(size varies)

Standard returns
Bead blasted

0 - 70% Return draft

Rail position options
Flushed to face/back
Center of rail (see detail DW)

Rail attachment bolts
(size varies)

Letter finish varies

Tie back boss
(see note)

NOTE:
Letters 4"-24", Minimum 3/8" thick
Tie back required (not supplied) on letters >8" high
Letters are mounted by word. Maximum 96" length

TITLE:

CAST METAL BOTTOM RAIL MOUNT

MATERIAL:

ALUMINUM OR BRONZE

PRODUCT TYPE:

CAST METAL

DWG NO. CAST60

REV 11/20/14

SCALE: AS INDICATED

SHEET 1 OF 1