

**FRONT VIEW SCALE 1 : 6**

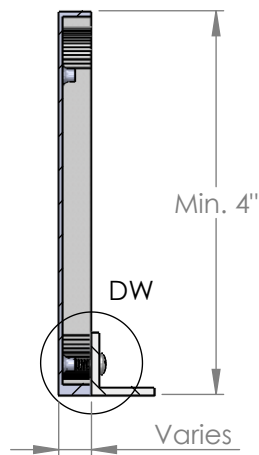

**SECTION A-A SCALE 1 : 6**

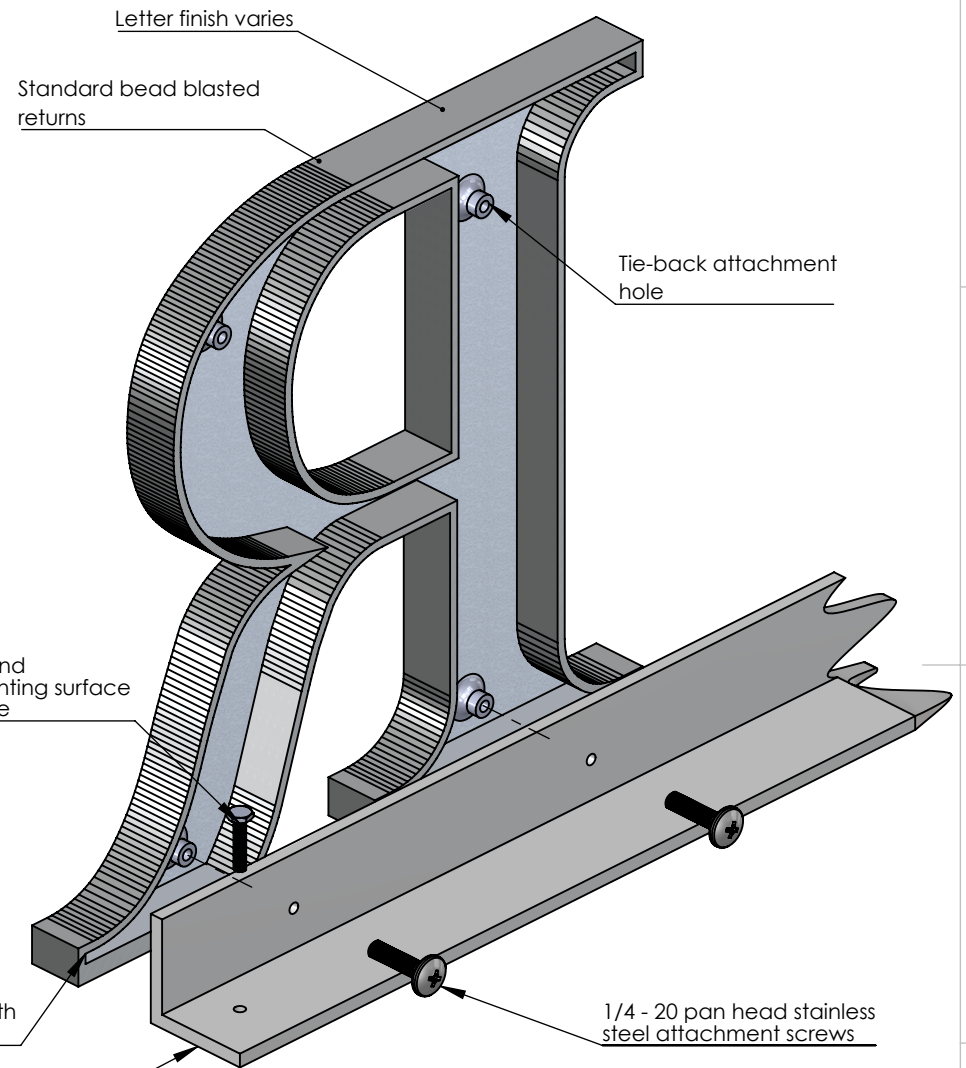

**ISOMETRIC BACK VIEW II SCALE 1:3**

Stud boss (size varies)

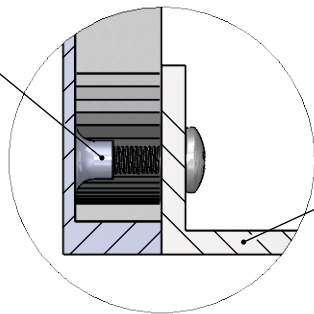

**DETAIL DW SCALE 1 : 2**

90 degree angle  
6061-T6 extruded-aluminum

0 - 7" return draft - thickness/depth  
- varies by style and height

Customer supplied mounting hole  
& hardware for all rail mounts

**NOTES:**

- Letters are pre-assembled to rails to ensure fit. Min. 2 screws per letter - Larger letters shipped loose.
- Min. 4" - 24" high letters, min. 3/8" thick, min. 1/2 stroke
- Optional rail lengths, up to 96", typically mounted by word
- Round letter bottoms - sanded flat - optional
- Rail finish: painted standard or custom color
- Tie-backs recommended on letters over 12" high (not supplied)
- Optional angle brackets: 2" x 2" x 1/4", 1 1/2" x 1 1/2" x 3/16", 1" x 1" x 3/16"
- Standard catalog styles or customer per vector art. Flat faced/round/prismatic profile options. Typical 3/16" - 1/4" wall thickness on hollow back letters/logos.
- Letters or logos, standard or custom

TITLE:

**CAST METAL BOTTOM ANGLE BRACKET MOUNT**

MATERIAL:

**ALUMINUM**

PRODUCT TYPE:

**CAST METAL**