

FRONT VIEW II SCALE 1:5

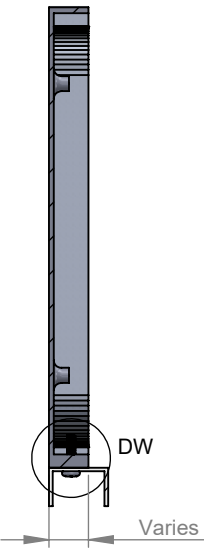

SECTION VIEW A-A II SCALE 1:5

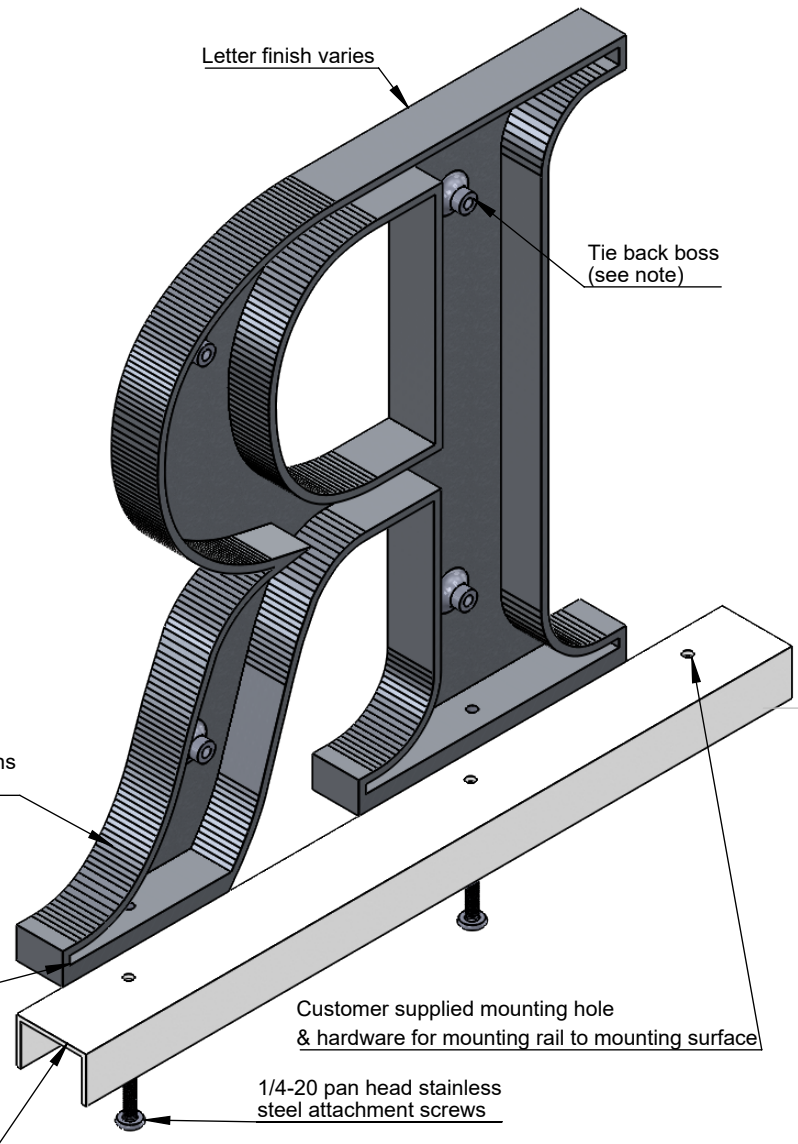

ISOMETRIC BACK VIEW II SCALE 1:3

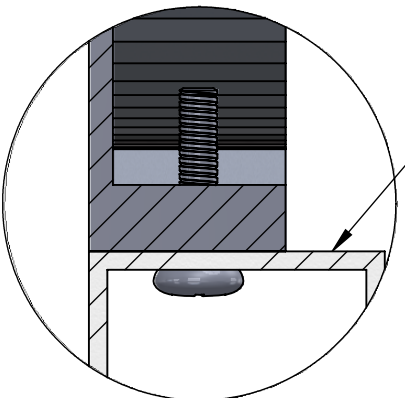

DETAIL DW II SCALE 1:1

C-shape rail (size varies)
Painted or anodized
6063-T2 extruded-aluminum
1/8" wall

Standard returns
Bead blasted

0 - 7° return draft - thickness/depth
- varies by style and height

Rail position options
Flush to face/back
Center of rail (see detail DW)

- NOTES:**
- Letters 4"-24", Minimum 3/8" thick
 - Tie back required (not supplied) on letters >8" high
 - Letters are mounted by word. Maximum 96" length
 - Standard catalog styles or customer per vector art. Flat faced/round/prismatic profile options. Typical 3/16" - 1/4" wall thickness on hollow back letters/logos.
 - Letters or logos, standard or custom
 - C-Channel (rail)
 - 1/2" deep x 1" or 1 1/2" wide x 96" long, painted or anodized
 - 1" deep x 2" or 3" wide x 96" long, painted or anodized
 - Rails pre-assembled for fit, larger letter may ship loose
 - Minimum 2 studs per letter
 - Round letters (O, C, G, J, Q, S, U) sanded flat - optional
 - Rail Mounting
 - C-channel rails are designed to be mounted to load bearing structures, holes and location to be determined by installer (rail mounting hardware not included)



TITLE: CAST METAL BOTTOM RAIL MOUNT

MATERIAL: ALUMINUM OR BRONZE

PRODUCT TYPE: CAST METAL

DWG NO. CAST60

REV 01/20/17

SCALE: AS INDICATED

SHEET 1 OF 1